

AUTOMATIC GRAVITY FILLER



APACKS' FGI-4000-AP Gravity Filler is ideal for filling thin liquids with consistent viscosity. Volumetric by time gravity filling method produces repeatable and accurate fill volumes.

The Gravity Filler is manufactured with a heavy duty 304 stainless steel, tig-welded tube frame. It also comes standard with PLC Controls and touch screen HMI, 304 stainless steel reservoir and fill head bar, available in 1 to 16 heads, and an automatic product level sensing float system, plus many more features. Options are available for even more versatility.

Gravity Fillers are used in the cosmetic, food and beverage, cleaning and specialty chemical, pharmaceutical, and personal care industries. APACKS' FGI-4000-AP can be built to suit sanitary, hazardous, flammable and corrosive environments.



SPECIFICATION

Standard Construction: Heavy duty 304SS, tig-welded tube frame

Number of Fill Heads: 1 to 16

Reservoir: 304SS tank is standard

Filling Size: 0.5oz to 5gal

Power Requirement: 115VAC, single phase, 20 amp, 50-60Hz

Air Requirement:

3-6CFM @ 90PSI clean, dry, compressed air

Dimensions & Weight: Subject to model configuration

Standard Features:

- 304SS Fill Head Bar
- PLC Controls with touch screen HMI
- 1/100th second individual Fill Head Control
- 316SS Drain Valve with Teflon seals
- Matching Throttle Valve for each Fill Head Valve
- Pneumatic Indexing Gates (Entry and Exit)
- Automatic product level sensing float system
- Front panel Start and Emergency Stop
- On/off and speed Controls for Conveyor
- No bottle/No fill Sensor
- Bottle Backup Sensor (downstream) delays operation until jam is cleared
- Mounted on 4 threaded leveling legs



AUTOMATIC GRAVITY FILLER



OPTIONS

- Drip Tray
- Container Neck Locators
- Starwheel or Timing Screw Indexing
- Proximity Sensor for cosmetic fill levels
- Pressure Assist for thick products
- Product Supply Pump
- Custom applications
- Special electrical requirements
- Lexan Safety Guarding
- Additional remote E-stops
- Sanitary, hazardous, flammable and corrosive environment construction

APPLICATIONS

- Water
- Fruit Juices
- Extracts
- Liquid Tea
- Liquid Coffee
- Food Coloring
- Vegetable Oil
- Milk
- Wine
- Tomato juice
- Some Salad
- Dressings Perfumes
- Essential Oils
- Ink
- Thin Liquid Soap
- Shampoo's
- Light Makeup remover
- Motor Oil
- Urethane
- Silicone
- Alcohol
- and many more

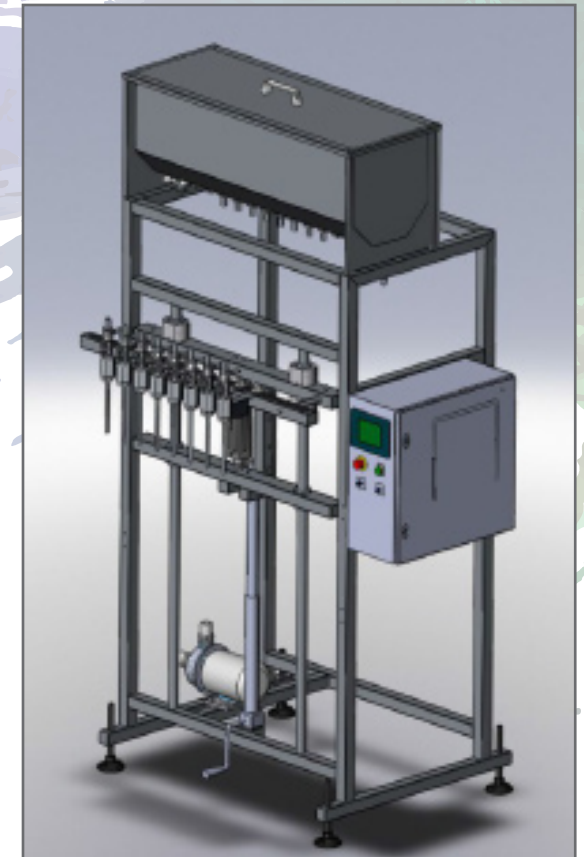
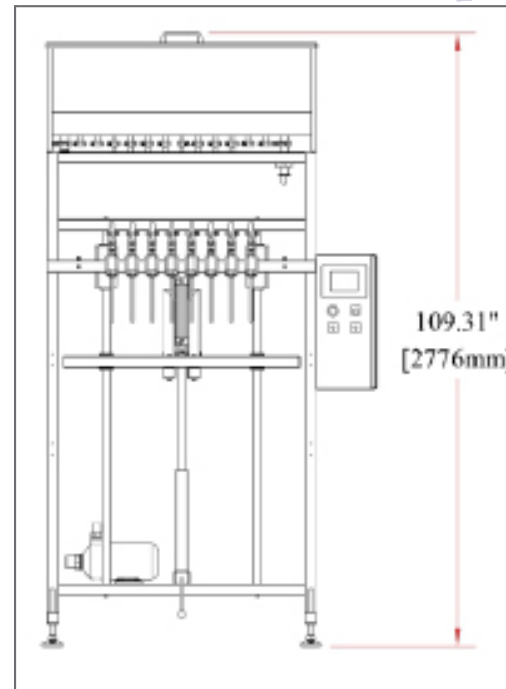
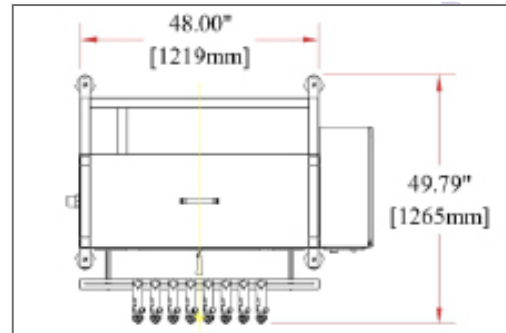

- **Complete line of filling and packaging solutions**
- **Standard filling machines in stock and ready to ship**
- **Economical prices, installation services and excellent customer service**

1500 Lake Street, La Porte, Indiana 46350
Local & Outside US: 219-369-4131
Toll Free: 866-369-9030
Fax: 574-975-2711

sales@apacks.com
www.apacks.com